

SMS AGM 400 Battery

Ultra High Performance AGM



NorthStar Specialty Marine & Stereo Batteries deliver **superior cranking, unrivaled cycling, and minimal maintenance.**

- Pure Lead AGM Technology delivers exceptional CCA ratings and reserve capacity cycling ability
- Quick starting every time
- Cycles over 400 times to 80% depth of discharge
- Faster recharge than conventional batteries
- Proudly made in the USA at our state-of-the-art battery plant
- Housed in advanced plastics for durability, performance and heat resistance
- Advanced AGM construction means no water levels to check or terminals to clean
- Approved as non-hazardous cargo for ground, sea, and air transport
 - DOT 49CFR173.159(d), (i) and (ii)

Visit our website to find out more www.northstarbattery.com



SMS AGM 400 Battery

Nominal Technical Specifications



BCI Group Number	Specialty
Height with Terminal	12.6 in
Width	4.9 in
Length with Rib	22.0 in
Weight	128 lbs
Terminal Configuration	Bolt in
Pulse Cranking Amps	2,150 A
CA/MCA Rating at 32°F	1,700 A
Cold Cranking Amps at 0°F	1,400 A
Cold Cranking Amps at -20°F	992 A
Reserve Capacity	400 min
Capacity - 20 Hour Rate	185.8 Ah
Capacity - 10 Hour Rate	176.5 Ah
Internal Resistance	2.7 mΩ
Short Circuit Current	6,000 A
Warranty	2 years full

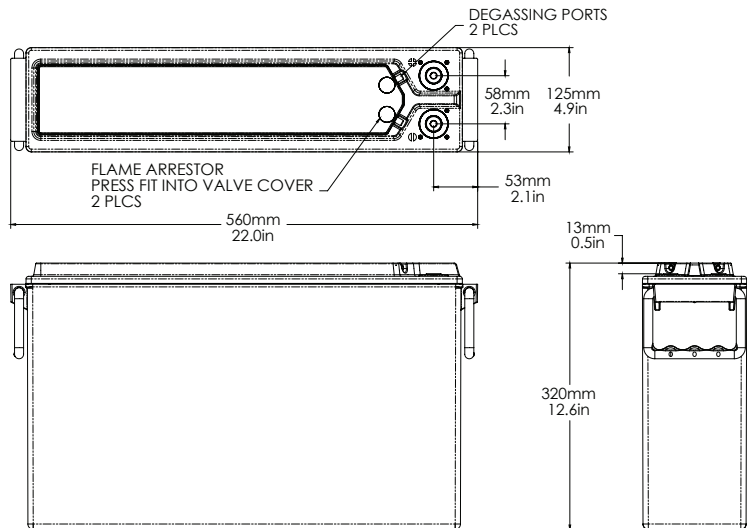

All NorthStar Batteries are proudly made in the USA using advanced manufacturing processes.



NorthStar batteries use pure lead AGM thin plate technology to deliver exceptional performance and longer lifetime.

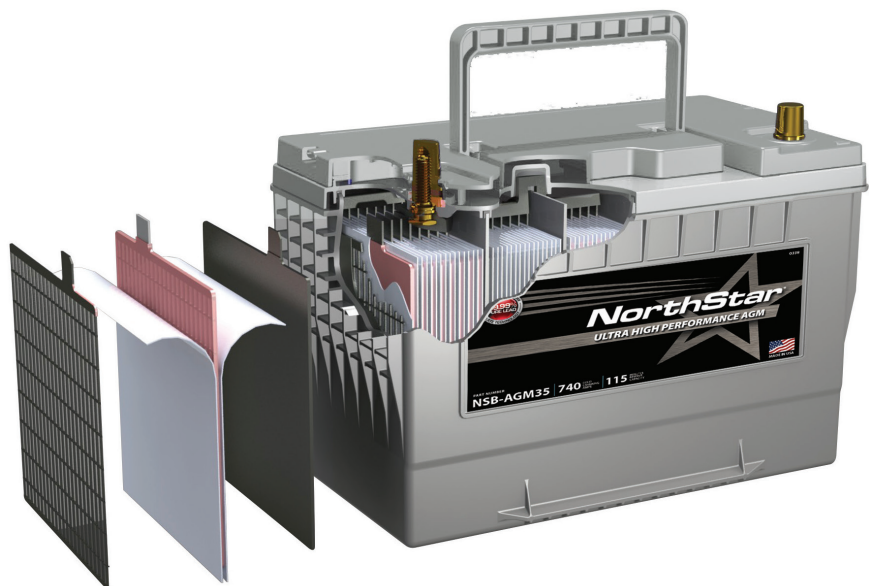

NorthStar Americas
NorthStar Battery Company LLC
4000 Continental Way
Springfield, MD, 65803,
United States of America
info@northstarbattery.com
Tel: +1 417 575 8200
Fax: +1 417 575 8250

NorthStar Europe
SiteTel Sweden AB
Staffans Väg 6-8
SE-192 07 Sollentuna,
Stockholm, Sweden
europe@northstarbattery.com
Tel: +46 8 410 102 00
Fax: +46 8 638 06 00

NorthStar Middle East, Africa
SiteTel Sweden AB JTL Branch
Office 702, Saba 1 Tower
Jumeirah Lake Towers, Dubai
United Arab Emirates
mea@northstarbattery.com
Tel: +971 4 423 8060
Fax: +971 4 423 8061

NorthStar Asia-Pacific
NS Asia Pacific Sdn. Bhd.
Lvl 20, Menara Standard Chartered,
30 Jalan Sultan Ismail, 50250
Kuala Lumpur, Malaysia
asia@northstarsitetel.com
Tel: +60 3 2117 5354

www.northstarbattery.com

